

ELECTRICAL CHARACTERISTICS

($T_a = +25^\circ\text{C}$, $V_{GG} = 1.5\text{V}$ unless otherwise specified)

Characteristic	Symbol	Test Conditions	MIN	TYP	MAX	Unit	Note
Input Voltage	V_{IH}		$V_{GG}-0.4$			V	1
	V_{IL}				0.4		
Input Current	I_{IH}	$V_{IN} = V_{GG}$			1	μA	2
	I_{IL}	$V_{IN} = 0\text{V}$	0.3	1	3		
Output Voltage 1	V_{OH}	without load	$V_{GG}-0.15$			V	3
	V_{OL}	$I_{out} = 15\mu\text{A}$			0.15		
Output Voltage 2	V_{OA}	without load	2.80	2.95		V	4
	V_{OB}	without load	1.30	1.50	1.70		
	V_{OC}	without load		0	0.20		
Display Frequency	F_d	$V_{GG} = 1.3\text{V}$ while display is on, $R_f=560\text{k}\Omega$	55	75		Hz	4
Dissipation	I_{OFF}	Display off			0.1		5
	I_{DIS}	$V_{GG} = 1.3\text{V}$ while display is on		1.5	3.5	μA	6
	I_{OP}	$V_{GG} = 1.3\text{V}$ while operation		5.6	8	μA	7

NOTE:

1. Applies to Pins K2-K6.
2. Applies to Pins K2-K6.
3. Applies to P1, P2, A2-A5.
4. Applies to H1-H3, a1-a9, b1-b8, c1-c8.
5. Measured by the next test circuit after power supply automatically turns off.
6. Measured by the next test circuit while "0" is being displayed after auto-clear operation and while key is not being depressed.
7. Measured by the next test circuit while operation is being made by ON/C key is not being depressed.

PAD DESCRIPTION

Pad	Signal	I/O	Description	Pad	Signal	I/O	Description
1	FODIS	I	Fosc disable	25	b3	O	Display output
2	EXTNL	I	External Clock	26	a3	O	Display output
3	VB	O	Capacitor terminal for voltage set-up	27	c2	O	Display output
4	VA	O	Capacitor terminal for voltage set-up	28	b2	O	Display output
5	VC	O	Capacitor terminal for voltage set-up	29	a2	O	Display output
6	GND		Ground	30	c1	O	Display output
7	H3	O	Display output	31	b1	O	Display output
8	H2	O	Display output	32	a1	O	Display output
9	c8	O	Display output	33	H1	O	Display output
10	b8	O	Display output	34	V _{GG}	I	Power supply
11	a8	O	Display output	35	Vop	O	Option Pin
12	c7	O	Display output	36	Vsb	I	Solar Battery
13	b7	O	Display output	37	K4	I	Key input
14	a7	O	Display output	38	K6	I	Key input
15	c6	O	Display output	39	K5	I	Key input
16	b6	O	Display output	40	P1	O	Strobe output
17	a6	O	Display output	41	P2	O	Strobe output
18	c5	O	Display output	42	A5	O	Strobe output
19	b5	O	Display output	43	A4	O	Strobe output
20	a5	O	Display output	44	A3	O	Strobe output
21	c4	O	Display output	45	A2	O	Strobe output
22	b4	O	Display output	46	K2	I	Key input
23	a4	O	Display output	47	K3	I	Key input
24	c3	O	Display output				

PAD DIAGRAM

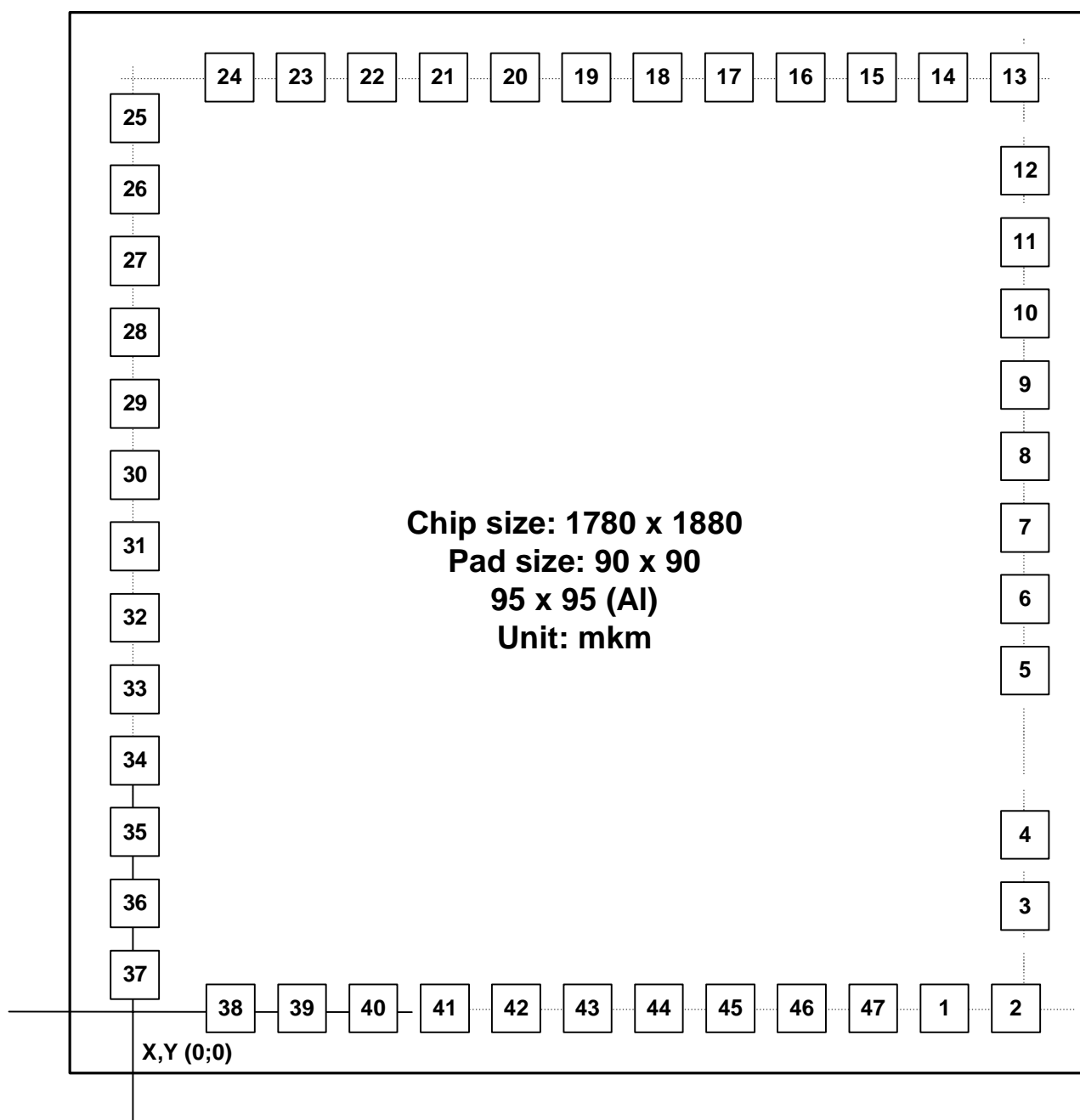

PAD LOCATION

Pad number	Pad name	X	Y	Pad number	Pad name	X	Y
1	FODIS	1380	0	25	b3	0	1566
2	EXTNL	1505	0	26	a3	0	1440
3	Ub	1519	176	27	c2	0	1314
4	Ua	1519	309	28	b2	0	1189
5	Uc	1519	569	29	a2	0	1064
6	GND	1519	695	30	c1	0	938
7	H3	1519	821	31	b1	0	813
8	H2	1519	947	32	a1	0	688
9	c8	1519	1072	33	H1	0	562
10	b8	1519	1198	34	V _{GG}	0	437
11	a8	1519	1324	35	V _{op}	0	312
12	c7	1519	1449	36	V _{sb}	0	187
13	b7	1505	1626	37	K4	0	61
14	a7	1380	1626	38	K6	127	0
15	c6	1254	1626	39	K5	252	0
16	b6	1129	1626	40	P1	377	0
17	a6	1004	1626	41	P2	503	0
18	c5	879	1626	42	A5	628	0
19	b5	753	1626	43	A4	753	0
20	a5	628	1626	44	A3	879	0
21	c4	503	1626	45	A2	1004	0
22	b4	377	1626	46	K2	1129	0
23	a4	252	1626	47	K3	1254	0
24	c3	127	1626				

APPLICATION CIRCUIT

(for use with dual power)

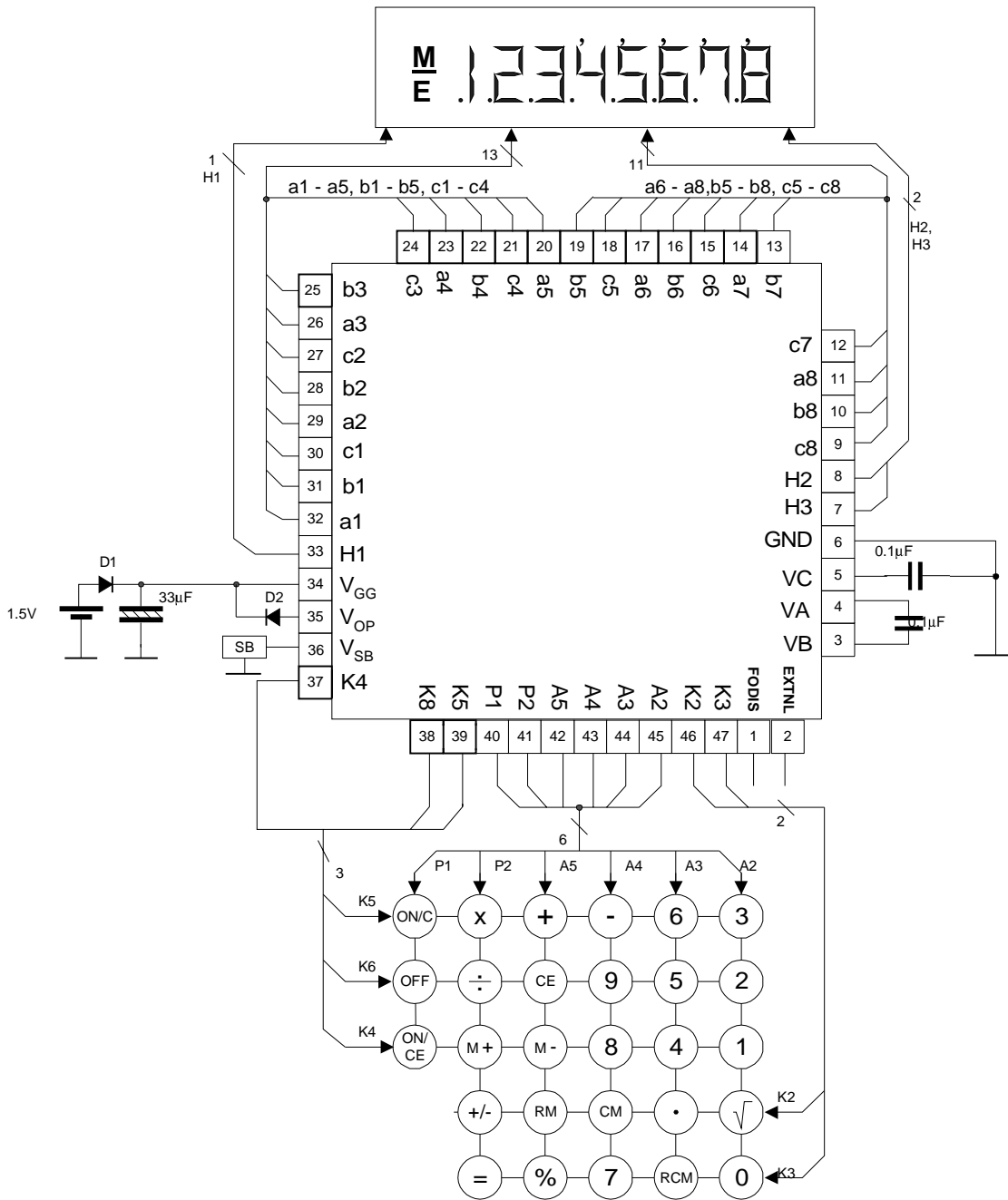

Note:

- SB: Solar Battery
- D1, D2 – diodes with $V_D < 0.1V$
- D1 – overcharge battery protection
- D2 – battery exhaust protection
- Application without D1 is permitted.

APPLICATION CIRCUIT

(for use with a solar cell)

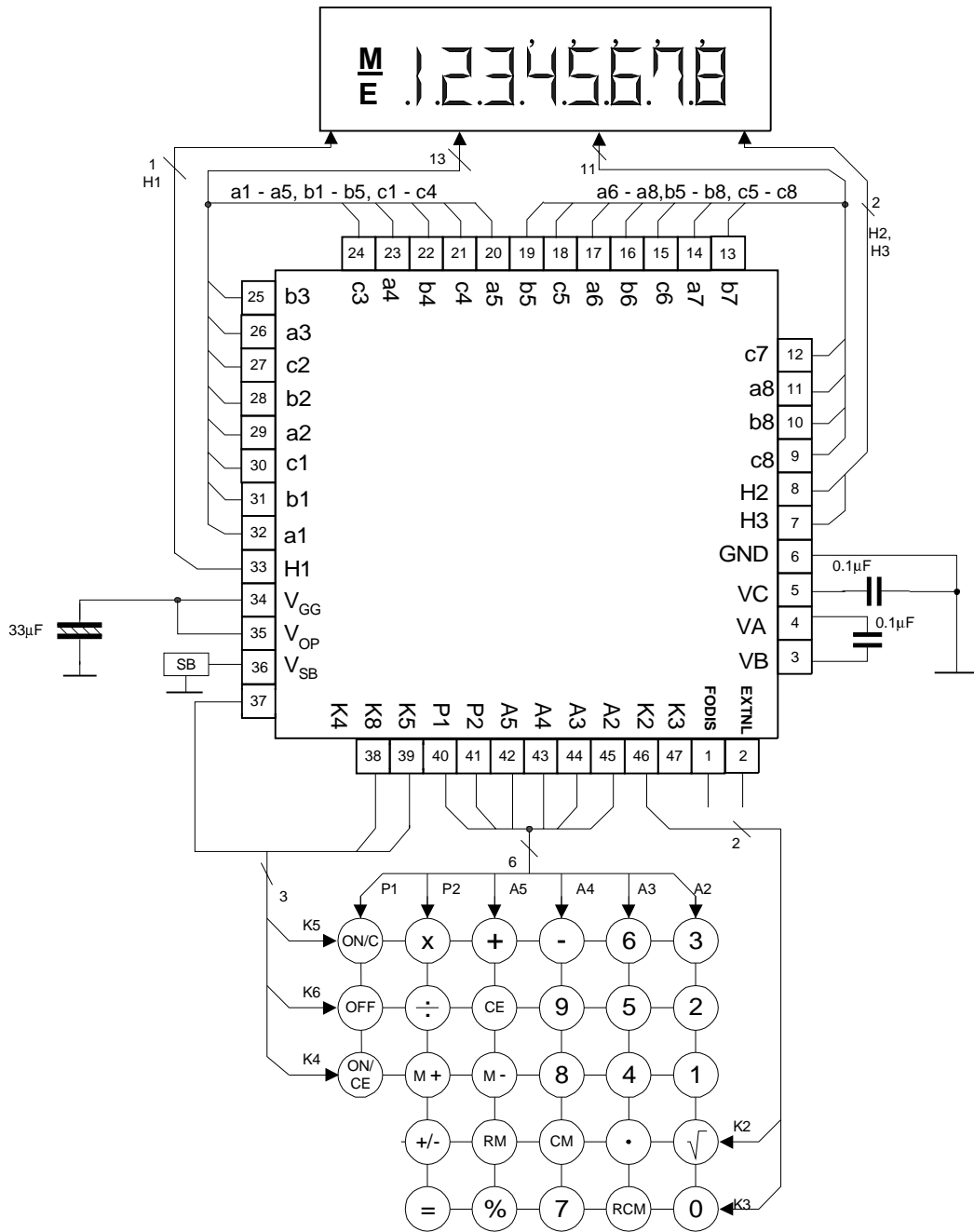

Note:

SB: Solar Battery

APPLICATION CIRCUIT

(for use with a cell)

